



Spent Fuel Security

Much of the discussion since the September 11th attacks on the World Trade Center and the Pentagon has focused on the resistance of reactor containment structures to aircraft strikes. The Nuclear Regulatory Commission (NRC) needs to analyze this issue so that its answer is known rather than debated.

More importantly, the NRC must address the vulnerability of spent fuel storage at all US nuclear power plants **now**. Spent fuel pools contain more highly radioactive fuel than the reactor cores. And the spent fuel pools at all US nuclear plants are located *outside* the reactor containment structure. When the spent fuel pools fill up, spent fuel is stored in concrete casks *outside* the plant. Thus, spent fuel is a softer target that could yield graver consequences than an aircraft crashing through the reactor containment structure.

What is the spent fuel pool?

The spent fuel pool is a 45-foot deep concrete pit that stores highly radioactive fuel assemblies after their removal from the reactor core. Water storage is required because spent fuel assemblies continue to emit considerable amounts of both heat and radiation for many years. The fuel pool water is continuously cooled to remove the heat produced by the spent fuel assemblies. Without cooling, the fuel pool water will heat up and boil. If the water boils or drains away, the spent fuel assemblies will overheat and either melt or catch on fire. NRC studies have estimated that many thousands of people living within 50 miles could die from the radiation released when spent fuel assemblies melt or catch on fire.

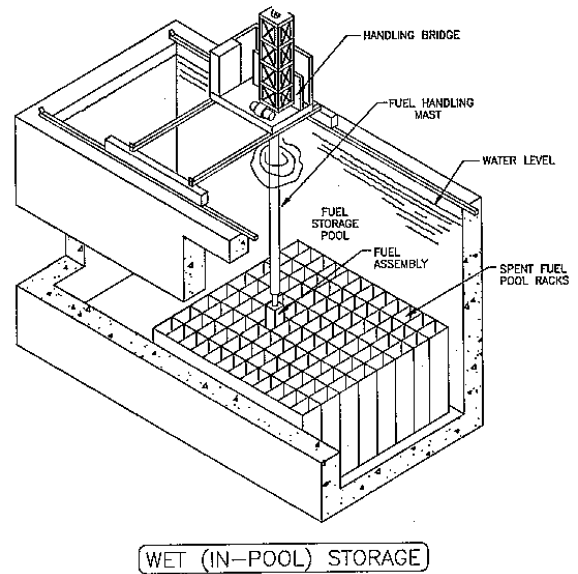

Where are the spent fuel pools located?

The spent fuel pools at nuclear power plants with pressurized water reactors are located in buildings adjacent to the reactor containment structures. Typically called the Fuel Handling Buildings, these structures are designed to withstand nature (e.g., earthquakes, tornadoes, hurricanes, floods, and snow storms) but not man (e.g., sabotage and accidental or intentional aircraft strikes). The Fuel Handling Buildings are basically standard, industrial-grade buildings (much like K-Mart but without the neon signs).

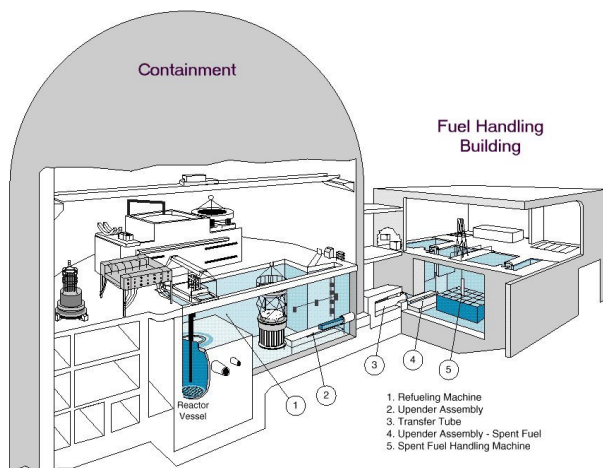

The spent fuel pools themselves are generally below ground level within the Fuel Handling Buildings. Consequently, it is less likely for water to drain out of the spent fuel pool when its floor or walls are damaged than if it were located above ground.

Spent Fuel Security

The spent fuel pools for nuclear power plants with boiling water reactors are located above ground in the building surrounding the primary reactor containment structure.



The photograph at left shows a boiling water reactor under construction. The steel foundation for the spent fuel pool's floor and walls is being erected. The large hole in the center of the photograph allows personnel to access equipment inside the reactor containment structure. A smaller hole in the lower left of the photograph, partially obstructed by reinforcing bar for an upcoming concrete pour, allows spent fuel assemblies to pass underwater from the reactor core to the fuel pool. As can be seen, the reactor containment structure is a steel-lined, reinforced concrete building whereas the spent fuel pool building is simply made of reinforced concrete.

The picture below shows the spent fuel pool in the completely constructed plant. The racks visible in the bottom of the pool store the spent fuel assemblies. The gap in the concrete wall in the lower right connects the spent fuel pool to the transfer area. Fuel assemblies are lowered from the vertical position to the

horizontal position in the transfer area for transport through the small containment hole to the reactor core.

The concrete wall on the far side of the picture, behind the railing and traversed by sheet-metal ventilation ductwork, is an outside wall. In the construction picture, this wall is represented by the reinforcing bars for the concrete.

An aircraft—or missile—would not need to completely level the fuel building to cause harm. It would merely need to crack the concrete wall or floor of the spent fuel pool and drain the water out. The spent fuel pool is designed to remain intact following an earthquake, but it is not designed to withstand aircraft impacts and explosive forces.

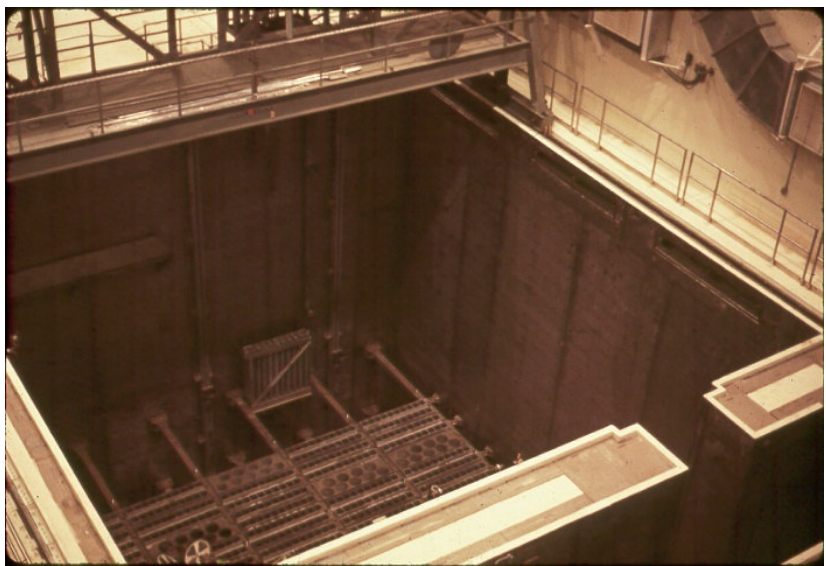

Spent Fuel Security

Some of the nuclear power plants with boiling water reactors are even more vulnerable. For example, the spent fuel pool is in the taller building on the left side of the nuclear plant shown below. The longer, shorter building on the right houses the turbine/generator. The photograph on the right shows the platform used to move fuel within the spent fuel pool. It rides on rails and spans the width of the spent fuel pool. The dark wall in the background is the blue panel shown in the picture on the left. It is corrugated metal siding that would hardly stop a Cessna from penetrating, yet alone a fully loaded commercial jet. As suggested from the photographs, the spent fuel pool at this plant is as high above ground as possible. About the only way to elevate it further would be to balance it on top of the red and white striped chimney in the background.



What about spent fuel stored in dry casks?

When the spent fuel pool in the “attic” of the nuclear plant fills up, some of the highly radioactive fuel assemblies are loaded into large casks and stored outside on concrete pads as shown below. Weapons available on the black market, and even some that can be legitimately purchased in the US, or explosives could cause the casks to be penetrated resulting in the release of large amounts of radiation. At some plants, the casks are line-of-sight visible from open access (i.e., unsecured) areas while other plants place casks inside unguarded chain-link fences.



What should the NRC do about spent fuel security?

Easy. Existing federal regulations (10 CFR 73.55) require plant owners to provide adequate security to protect spent fuel—whether stored in pools or casks—from radiological sabotage. All the NRC needs to do is simply enforce regulations already on the books. No more studies are required, no more rulemaking is needed, no more evaluations are necessary, and no more delays are warranted.