



VERMONT YANKEE EVENT

Nuclear Regulatory Commission (NRC) Daily Event Report No. 41868 dated July 25, 2005, provided preliminary information about an event occurring that day at the Vermont Yankee nuclear plant. This issue brief translates the nukespeak in that report into plain English:

Report	Translation
<i>At 1525 the plant experienced a load reject generator trip due to a catastrophic failure in the 345 kV switchyard. A reactor scram occurred as a result.</i>	At 3:25pm, a serious electrical problem at Vermont Yankee caused the main generator to automatically trip offline which in turn caused the nuclear reactor to automatically shut down. The 345 kV switchyard is shown in the upper left of Figure 1. The main generator is the circle around the “Y” in the lower center with the label “VY GEN.”
<i>The degraded AC power system prevented a fast transfer from occurring.</i>	The trip of the main generator meant that less electricity flowed through the No. 2 Auxiliary Transformer and Breaker 12 to Bus 1 and Breaker 22 to Bus 2. This power supply reduction prevented the automatic transfer of Bus 1 and Bus 2 from the No. 2 Auxiliary Transformer to the Startup Transformer. By design, a fast transfer would have quickly closed Breaker 12 for Bus 1 and immediately opened Breaker 13 while Breaker 22 would have closed fro Bus 2 while Breaker 23 opened.
<i>Degraded bus voltage caused the emergency diesel generators (EDGs) to start.</i>	The power supply reduction to Bus 1, which in turn meant less power though Breaker 3T1 to Bus 3, and to Bus 2 (and via Breaker 4T2 to Bus 4) caused the two emergency diesel generators – shown as the circles around the reclining Y’s – to automatically start.
<i>A residual bus transfer restored power to the 4 kV busses.</i>	Bus 1 and Bus 2 were realigned from the No. 2 Auxiliary Transformer to the Startup Transformer. The Startup Transformer was being powered from the 115 kV switchyard (upper right) so power was restored to Busses 1, 2, 3, and 4.
<i>The [main steam isolation valves] MSIVs closed on a low-low reactor water level of 82.5 inches. [Reactor Core Isolation Cooling] and [High Pressure Coolant Injection] (HPCI) also started on the low-low reactor vessel water level.</i>	As shown in Figure 2, the normal water level in the reactor vessel is about 14 feet above the top of the reactor core. The collapsing of bubbles when the reactor automatically shut down – similar to the effect of lifting a boiling pan of water off a stove – along with the increased pressure resulting from the closure of the turbine inlet valves drove the water level down about seven feet to the level where the main steam isolation valves (MSIVs) automatically closed and the Reactor Core Isolation Cooling (RCIC) and High Pressure Coolant Injection

Report	Translation
	(HPCI) systems automatically started. The MSIVs are not shown in Figure 3, but are located in the main steam line in the upper right between the reactor vessel and the main turbine. They automatically close on low-low water level inside the reactor vessel to prevent further loss of cooling water inventory. The HPCI system (shown on the right side of Figure 3) uses a steam-driven pump to provide makeup water from the Condensate Storage Tank to the reactor vessel. The RCIC system (not shown on Figure 3 but very similar) also employs a steam-driven pump to transfer water from the Condensate Storage Tank to the reactor vessel.
<i>The [Safety Relief Valves] were cycled twice for pressure control.</i>	The safety relief valves (shown as the bent bowtie to the lower right of the reactor vessel in Figure 3) allow steam from the main steam lines to flow into the water-filled torus (shown as the two circles on either side of the inverted lightbulb that is the drywell containment structure). The closure of the MSIVs bottled up the steam produced by decay heat from the shut down reactor core. The safety relief valves opened and closed twice to give that steam someplace to go and reduce pressure inside the reactor vessel.
<i>EOP-3 was entered due to elevated torus water temperature and both loops of [Residual Heat Removal] (RHR) are in torus cooling.</i>	The steam flowing through the safety relief valves into the water-filled torus warmed up that water. To cool the torus water, both RHR loops (each loop consisting of an RHR pump and an RHR heat exchanger) took water from the torus, cooled it, and returned it to the torus. Operators at Vermont Yankee followed Emergency Operating Procedure No. 3 to guide their actions.
<i>Water level has restored and is being maintained by feedwater. The MSIVs have been reopened and the scram reset. EDGs were secured.</i>	The HPCI and RCIC systems added sufficient water to the reactor vessel to raise the level back to the normal level. The MSIVs were opened and the normal feedwater system used to keep the reactor vessel water level at the normal level. The emergency diesel generators were manually turned off.
<i>The licensee is currently investigating the event in the switchyard.</i>	They don't yet know why it happened.

NOTE: Figure 1 shows the Vermont Yankee switchyard. Figures 2 and 3 illustrate reactors like that at Vermont Yankee.

Prepared by: David Lochbaum

FIGURE 1

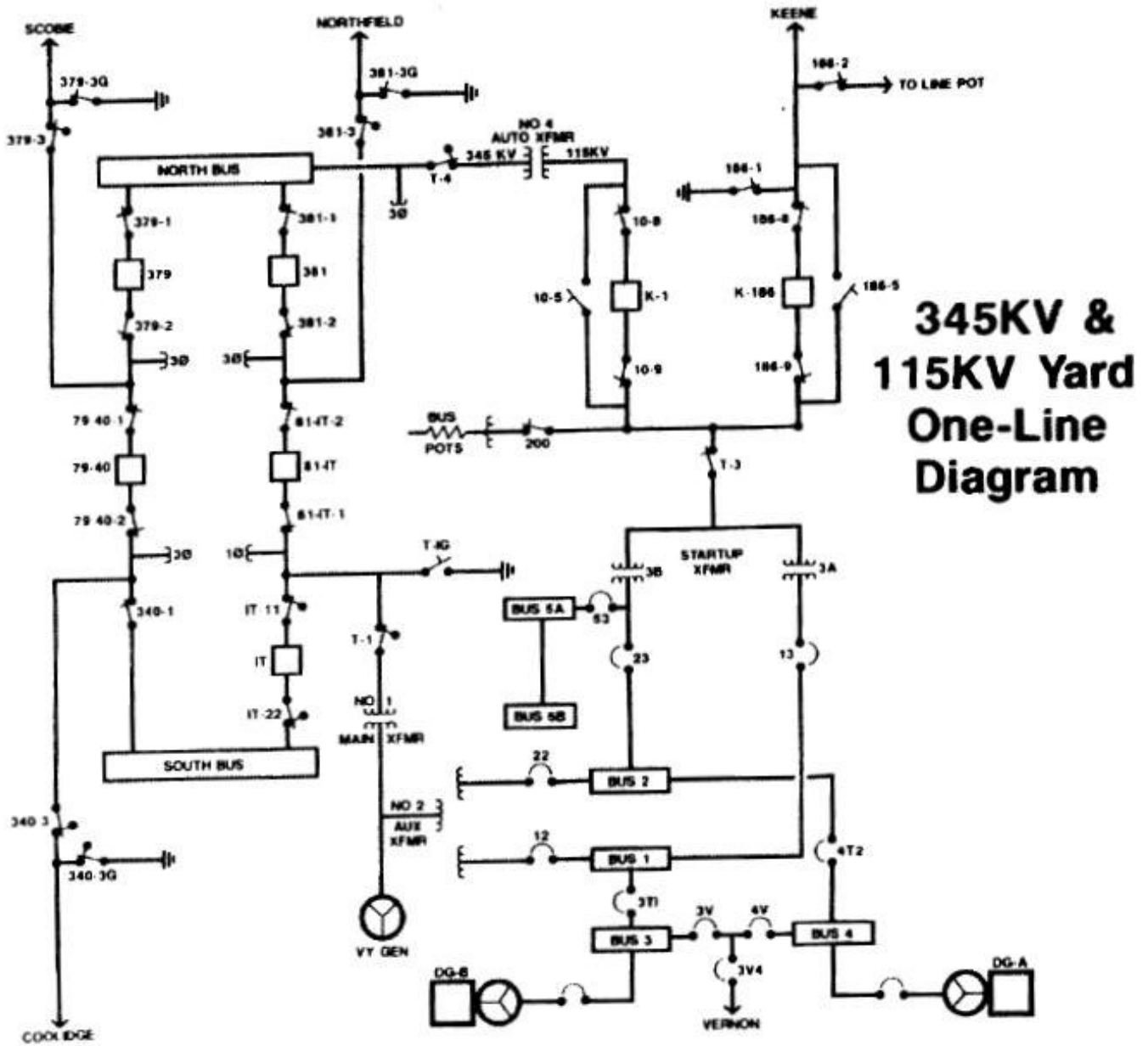
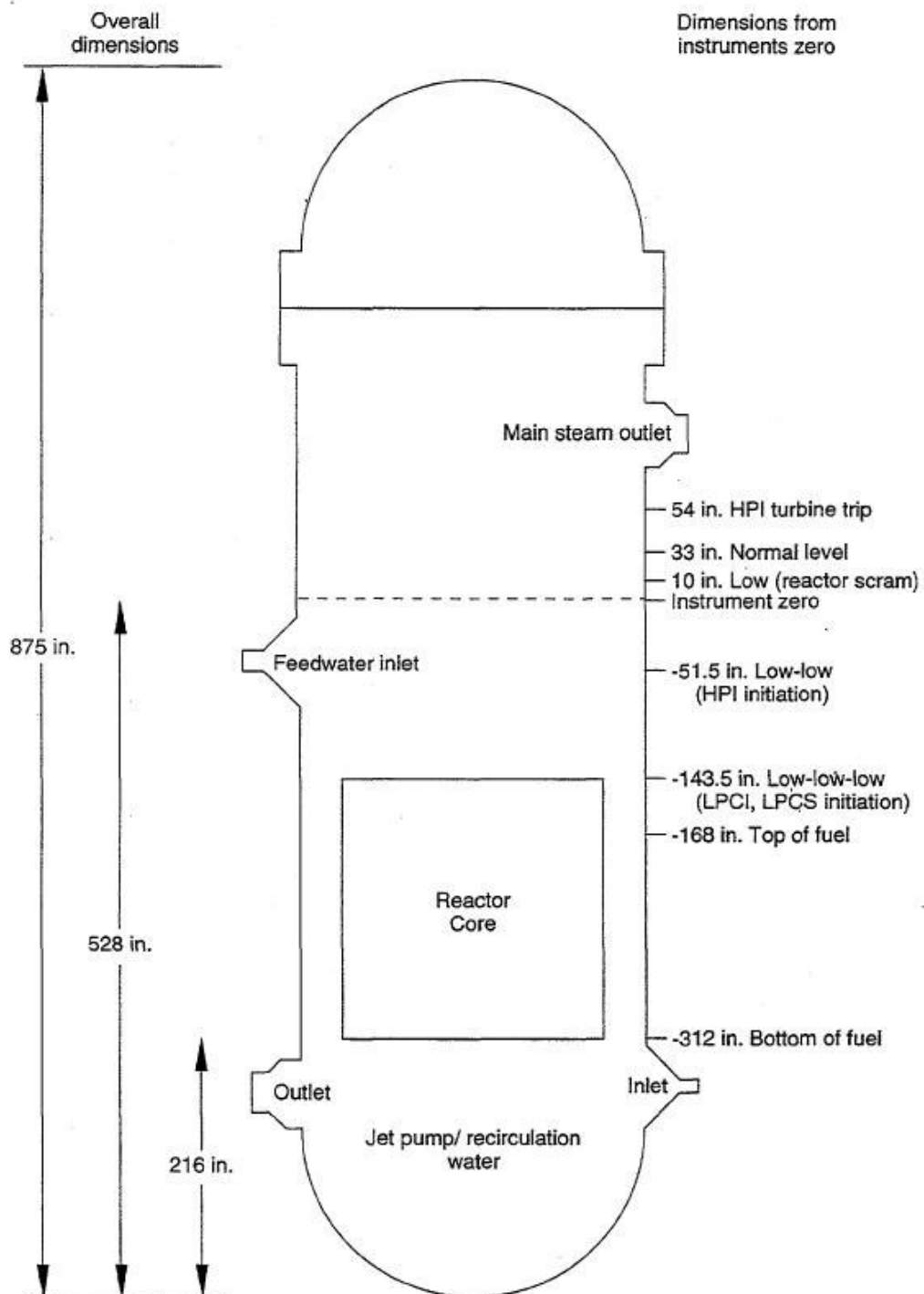

FIGURE 2



Typical reactor vessel water level points and overall dimensions

FIGURE 3

